

T1: Solenoid and loop

A closed circular loop of wire of radius r and resistance R is connected to an ideal battery of electromotive force \mathcal{E} . A long, thin, air-cored solenoid is aligned with the axis of the loop (z -axis). Its length is $\ell \gg r$, cross-sectional area is A ($\sqrt{A} \ll r$), and the number of turns is N . The solenoid is powered by a constant current I provided by an ideal current source. The directions of the currents in the solenoid and in the loop are the same (clockwise in the figure).

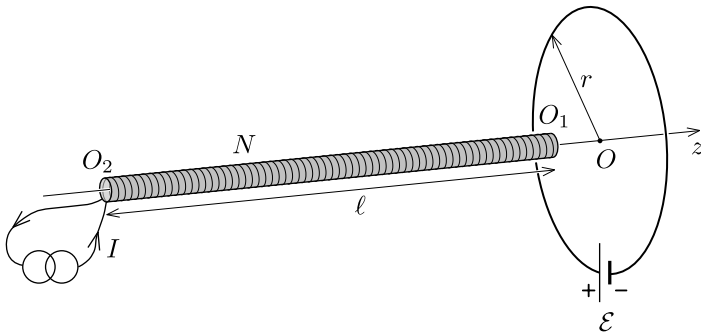

- Find the force F_1 acting on the solenoid when its head O_1 is positioned in the loop centre O . What is the force F_2 acting on the solenoid when its tail O_2 is located in the centre of the loop?
- Suppose now, that the solenoid is moving slowly with a constant velocity v along z -axis, starting far away from the loop, going past its centre, and proceeding further to the right in positive z -direction. Plot the current J flowing in the loop as a function of time. Highlight important features and values on the graph. The velocity v is so small that self inductance of the loop can be neglected.

T2: Mechanical accelerator

A light, inextensible, but flexible, thread makes N turns around a fixed, frictionless cylinder, as shown in the figure. Initially, the free (unwound) ends of the thread are parallel to the X axis. A massive point-like object P is attached to one end of the thread and the other end is pulled with a constant velocity u along X .

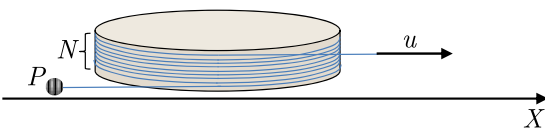

Suppose that the turns of the thread are wound tightly to one another and are placed practically in the same plane, perpendicular to the cylinder axis. Neglect any friction in the system. Do not consider the effect of gravity. Find the maximum velocity attained by the massive object.

T3: Cat eyes

You may have noticed that in the dark, when a cat is within the light beam of a headlamp, its eyes appear very bright; see the photo (below left). This phenomenon can be modelled by a lens setup, see the photo (below right), and the diagram beneath the photos.

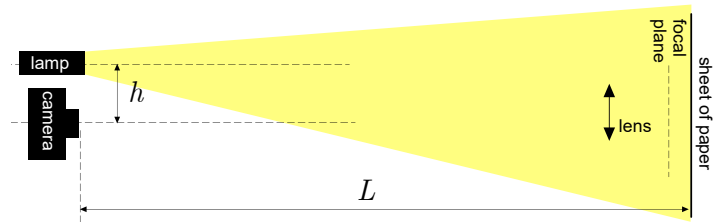

The photo on the right was taken by a digital single-lens reflex camera. The light intensity at the camera sensor pixels marked by a red line (in the photo) is shown in the graph below: the log base 10 of the light intensity (measured as the number of photons caught by each pixel) is plotted against the x -coordinate, with the pixel's side length serving as the unit of length.

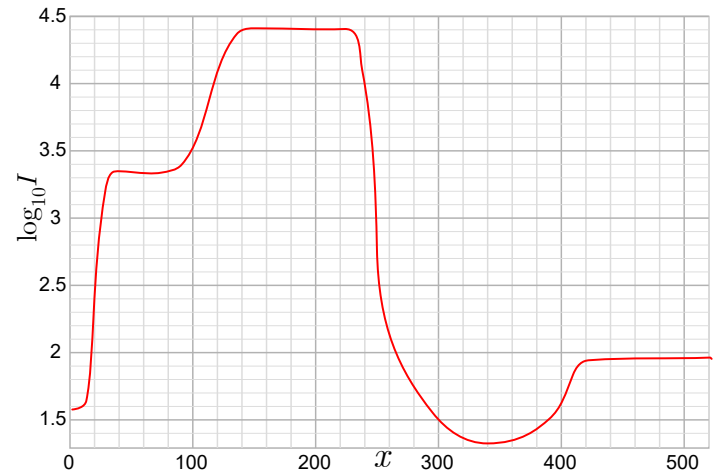

The lens can be treated as an ideal thin lens of focal length $f = 55$ mm and diameter $D = 39$ mm; however, you should keep in mind that the given graph shows real measurement data, and the lens has certain non-ideal features. Most importantly, partial reflections of the brightly lit areas from the lens surfaces may decrease the contrast: the dark areas seen through the lens appear less dark than they actually are; this effect can be neglected for the camera lens, but not so for the lens serving as a model of a cat's eye.

Based on the given data, estimate (with the accuracy of *circa* 20%) the distance h between the axis of the camera and the axis of the lamp (which can be considered as a point source) if the distance of the camera from the paper sheet was $L = 4.8$ m.